



Joint NextETRUCK - ESCALATE event

Istanbul, April 2026

Introduction to the pilots: Barcelona and UK

Jean-Charles Pandazis (ERTICO-ITS Europe)

jc.pandazis@mail.ertico.com



Co-funded by
the European Union



Co-funded by
UK Government

This project has received funding from the European Union's Horizon Europe programme under grant agreement No 101056740





NextETRUCK: From Objectives to Evaluation with demonstration

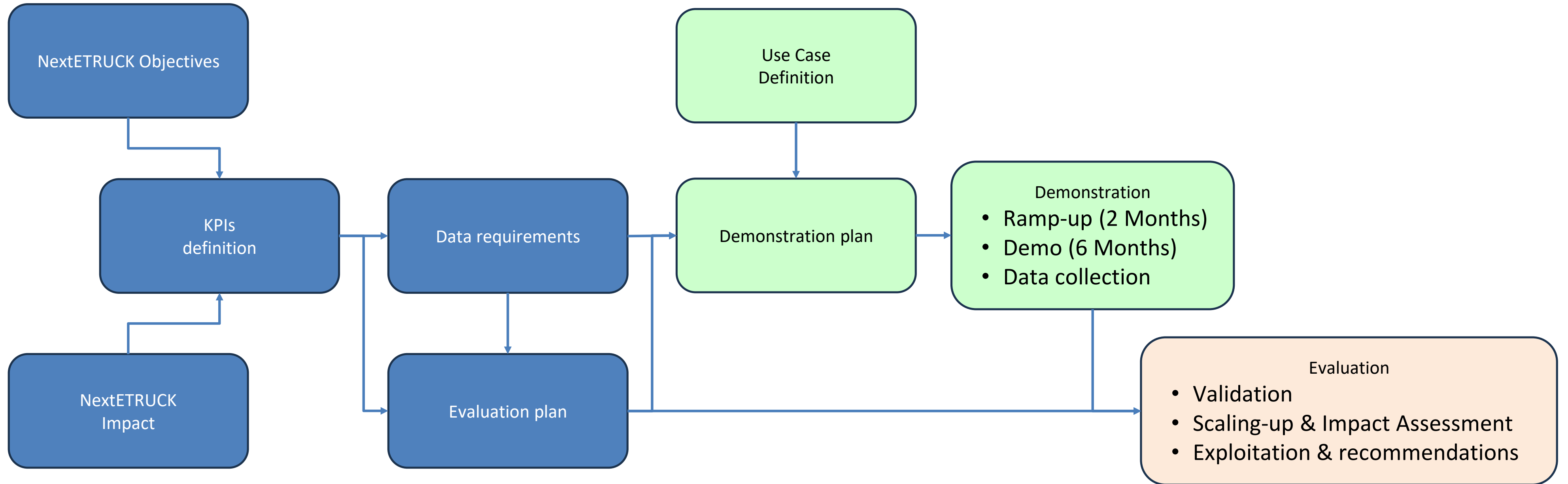



NextETRUCK Use Cases and pilot sites



Use case #1: Distribution Logistics in Istanbul

Ford Otosan will operate their demo truck in Turkey transporting parts between two manufacturing plants



Use case #2: Voluminous waste collection in Barcelona

A refuse truck from **IRIZAR** in Barcelona will be operated by a waste collection & recycle company



Use case #3: Pallet Delivery Logistics in UK

Pallet Delivery Logistics by Matthew Kibbles Transport via **DAF** and deploy multiple NextGEN vehicles to improve the EV performance, optimize TCO and integration of BEVs into logistic fleets.





Harmonised objectives for Use case and Pilots

#	Harmonised Objectives between pilot sites
#1	10% improvement in overall efficiency
#2	Demonstrate at least 200 km average daily operation in real conditions over a period of at least 6 months
#3	90% Payload capacity (in comparison to an ICE truck)
#4	Chassis development & integration of Next gen power electronic <ul style="list-style-type: none">• IST : Development of lightweight chassis and integration of electric powertrain components• BAR: Development and validation of tools for zero tailpipe emission vehicles integration in fleets
#5	Digital twin of the vehicle
#6	Fast charging, battery control & energy management (with charge planning & management)



KPIs & Data Requirements

KPI id	KPI title	UC id	Category
KPI-1a	Efficiency Increase & Payload Capacity Distance: <i>Driven per Absolut Energy Consumption</i>	All 3	ET
KPI-1b	Efficiency Increase & Payload Capacity Distance: <i>Load per mission</i>	1 & 3	ET
KPI-2	Thermal management system efficiency	All 3	ET
KPI-6a	TCO reduction of ZEV: <i>vs modern e-trucks</i>	All 3	UA
KPI-6b	TCO reduction of ZEV: <i>parity with ICE 2020 trucks</i>	All 3	UA
KPI-7	Charger efficiency	All 3	ET, CI
KPI-8	Vehicle thermal efficiency	All 3	ET
KPI-10	TCO reduction of charging	All 3	UA
KPI-12a	Charging experience: <i>user perspective</i>	All 3	UA
(...)	(...)	(...)	(...)
KPI-18	The NextETRUCK overall system is compatible with the driving/mission tasks	All 3	UA
KPI-20	Reduction in operational CO ₂ emission	All 3	ET, 2ZERO
KPI-21	Operating hours	All 3	ET, 2ZERO
KPI-22	Charging rate	All 3	ET, CI, 2ZERO
KPI-23	Charging time	All 3	ET, CI, 2ZERO
KPI-24	Driving to charging time	All 3	ET, CI, 2ZERO
KPI-25	Average driving speed	1 & 3	ET, 2ZERO
KPI-26	Charging cost per km	All 3	ET, CI, 2ZERO

ET = eTruck

CI = Charging Infrastructure

UA = User Acceptance



KPIs for measuring the performance of NextETRUCK systems across each UC.



KPIs are categories as follow:

- e-Truck (ET),
- Charging Infrastructure/Efficiency (CI)
- User Acceptance (UA)
- The listed KPIs relate specifically to real-life demonstrations. F

Quantified KPIs are defined in the Evaluation plan => **Requirements on data to be collected**



UA KPIs will be derived from Questionnaires to **Drivers, HMI use, Fleet manager**





KPIs & Data Requirements / 2ZERO

- ■ ■ ■ Liaison avec LeMesurier (CSA, to assess **2ZERO** partnership projects)

KPI to be measured

Link to the NextETRUCK questionnaire related KPI's: [NextETRUCK](#)

- There are 21 KPIs with a set of questions to be answered per KPI.
- Each KPI might require about 30 min, if you look into deliverables and transform the confidential content into less confidential.
- **How to answer and address all this?**



Use Case #2: Barcelona



Use case (UC) title	Voluminous waste collection <i>with 20t eTruck and (tbc) kWh battery</i>
Addressed challenge(s)	90% ICE truck payload with a range >200km.
Mission description % among all mission	Large dimension waste collection (furniture, electronic devices, etc.). It is not a repetitive route, as it is on demand service. It could be that the route does not reach 200km, depending on the demand.
Charging requirements	DC overnight charging.
Charging infrastructure	JEMA CCS2 DC charging (180KW DC)
Charge management	Cloud-based software solution for charge planning and shifts scheduling (PANION / ABB)

Route

- The vehicle will operate in Barcelona in l'Example, Gracia and Ciutat Vella neighbourhood or areas
- The route will depend on the daily demand.
- It will make a route of 10-20 voluminous goods pick up and will drive to the goods/waste treatment facilities. It can repeat this sequence for 4-5 times per journey

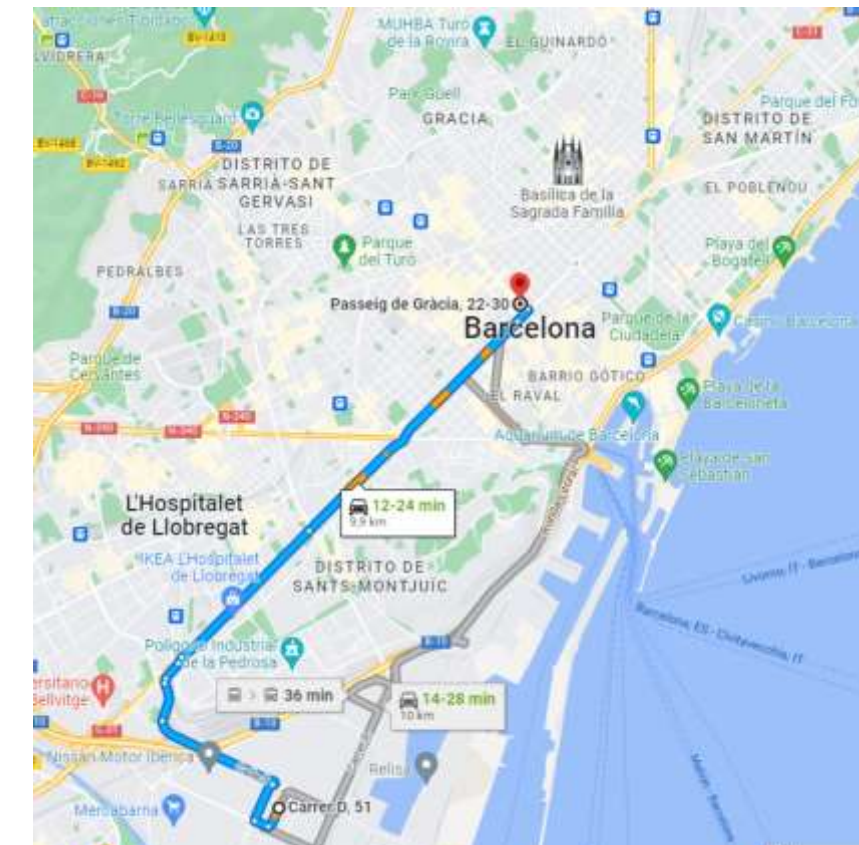
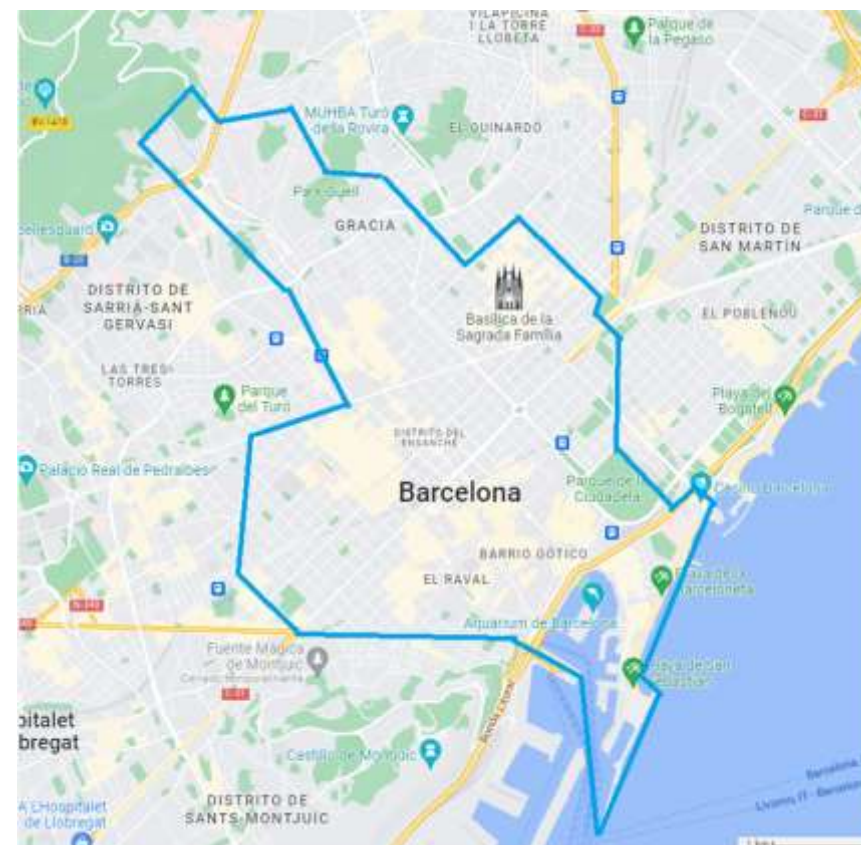



Truck features

Features:

- 4x2
- Open box
- 100% electric
- Category: N3
- Tare weight: 14.4 ton
- Gross vehicle weight: 20.5 ton





Innovation: Computational Fluid Dynamics (CFD) Study

CFD study:

- Baseline truck
- Aerodynamic improvements

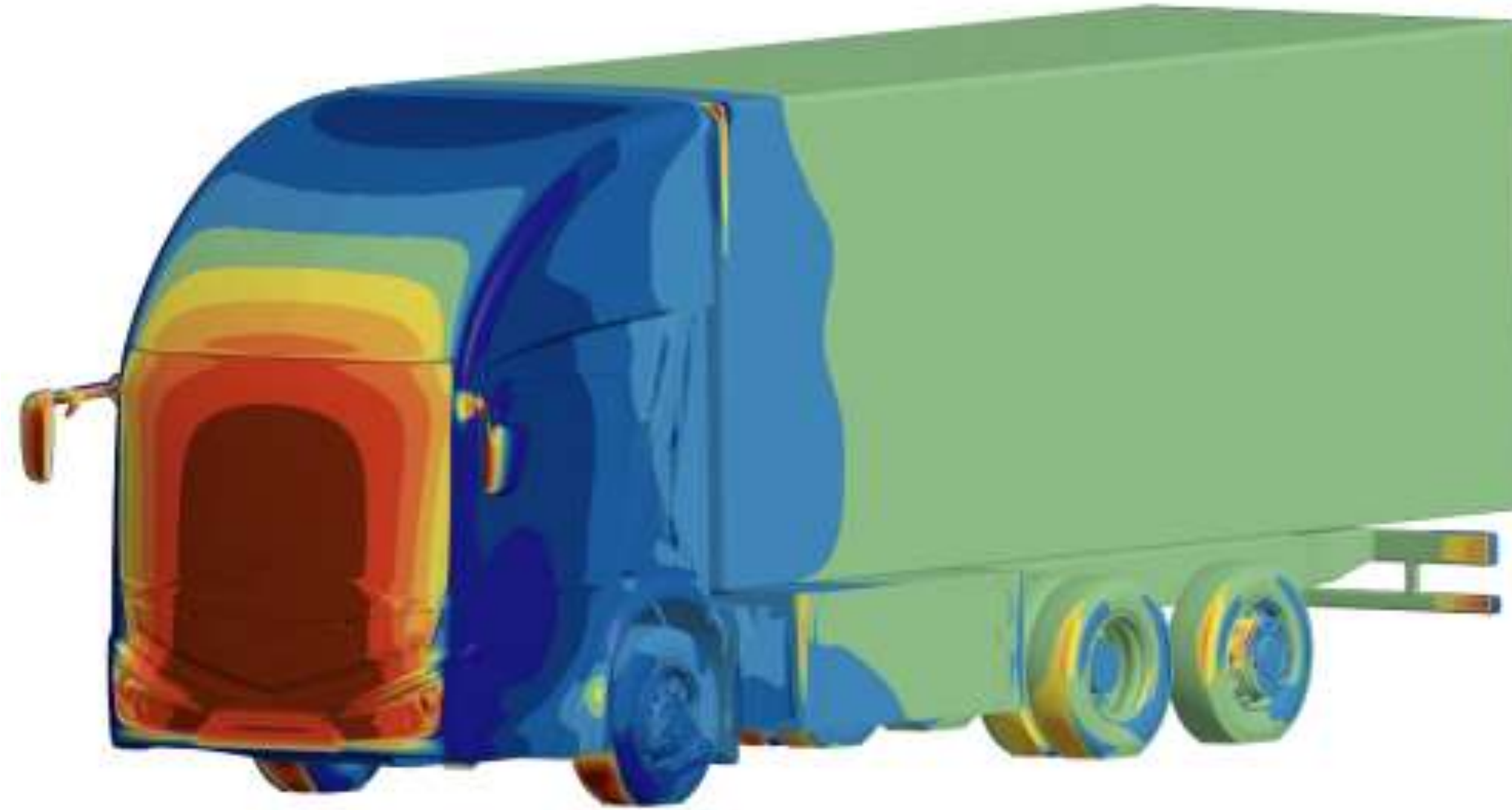



Innovation: HV Battery

	Baseline	Upgrade	Delta
Cells	NMC II	NMC III	-
No. UBPs	4	3	↓ -1
Energy	170 kWh	307 kWh	↑ 81 %
Weight	1400 kg	1575 kg	↓ +175 kg
Energy density	121 Wh/kg	196 Wh/kg	↑ 62 %





Innovation: HVAC-BTMS

BASELINE

BTMS

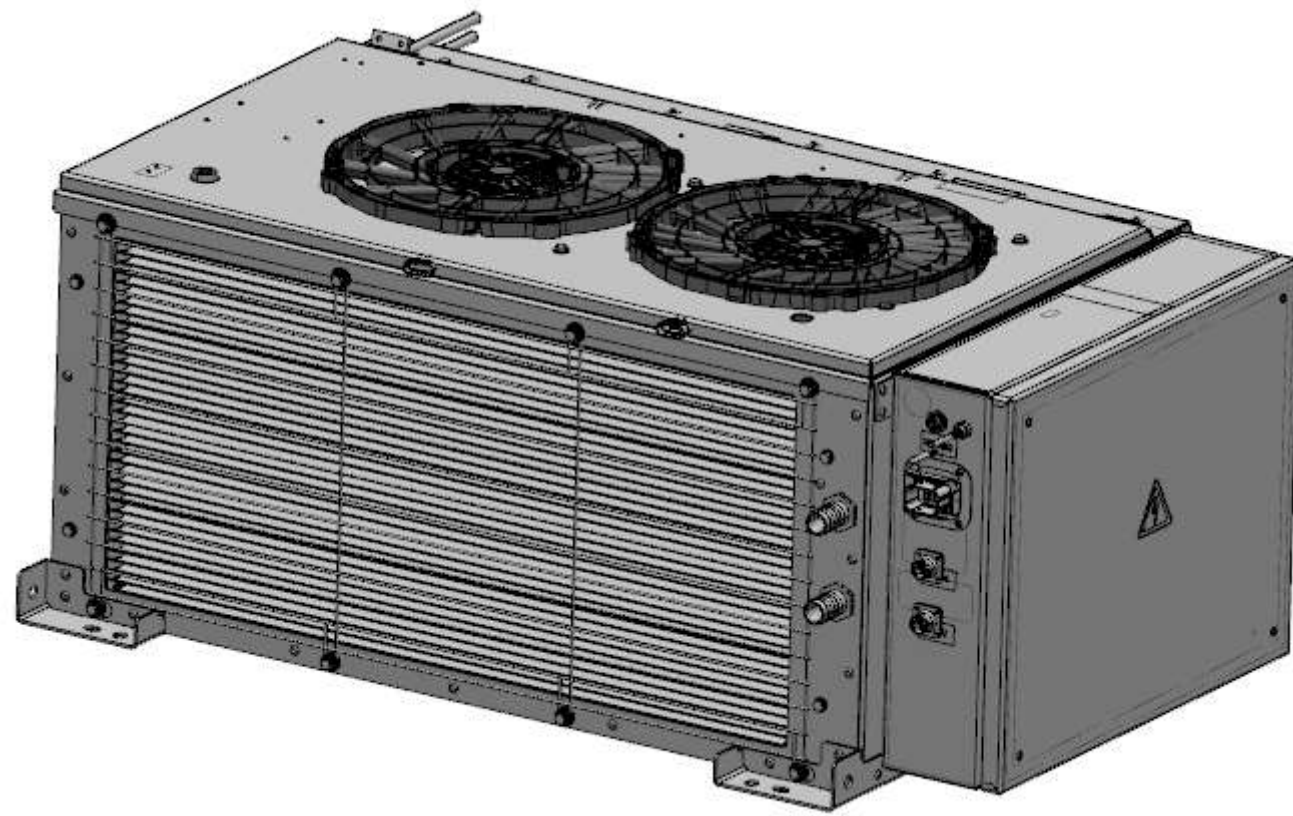

HVAC

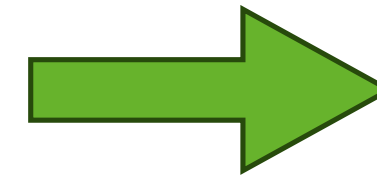

RETROFIT

BTMS-HVAC

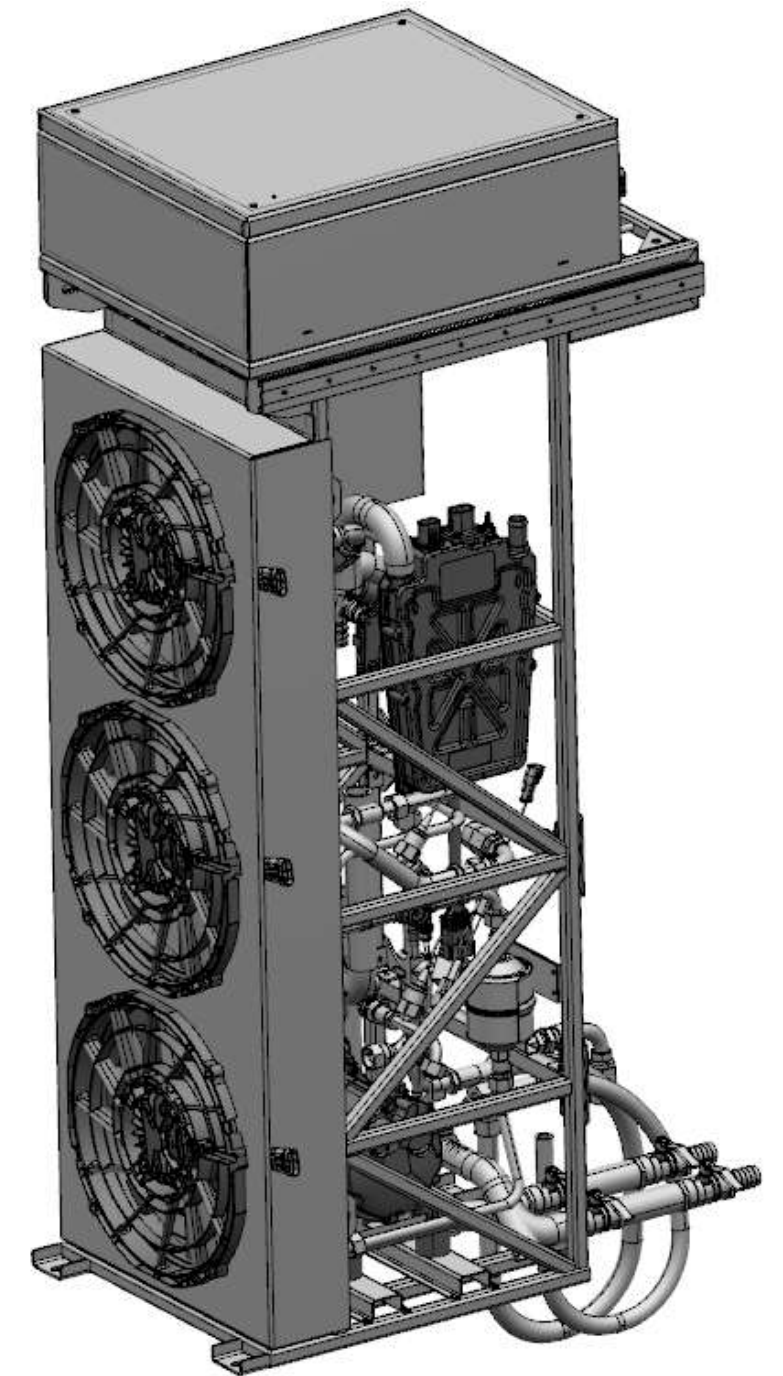

HVAC: Cabin air conditioning
BTMS: Battery cooling



Innovation: HVAC-BTMS

BASELINE

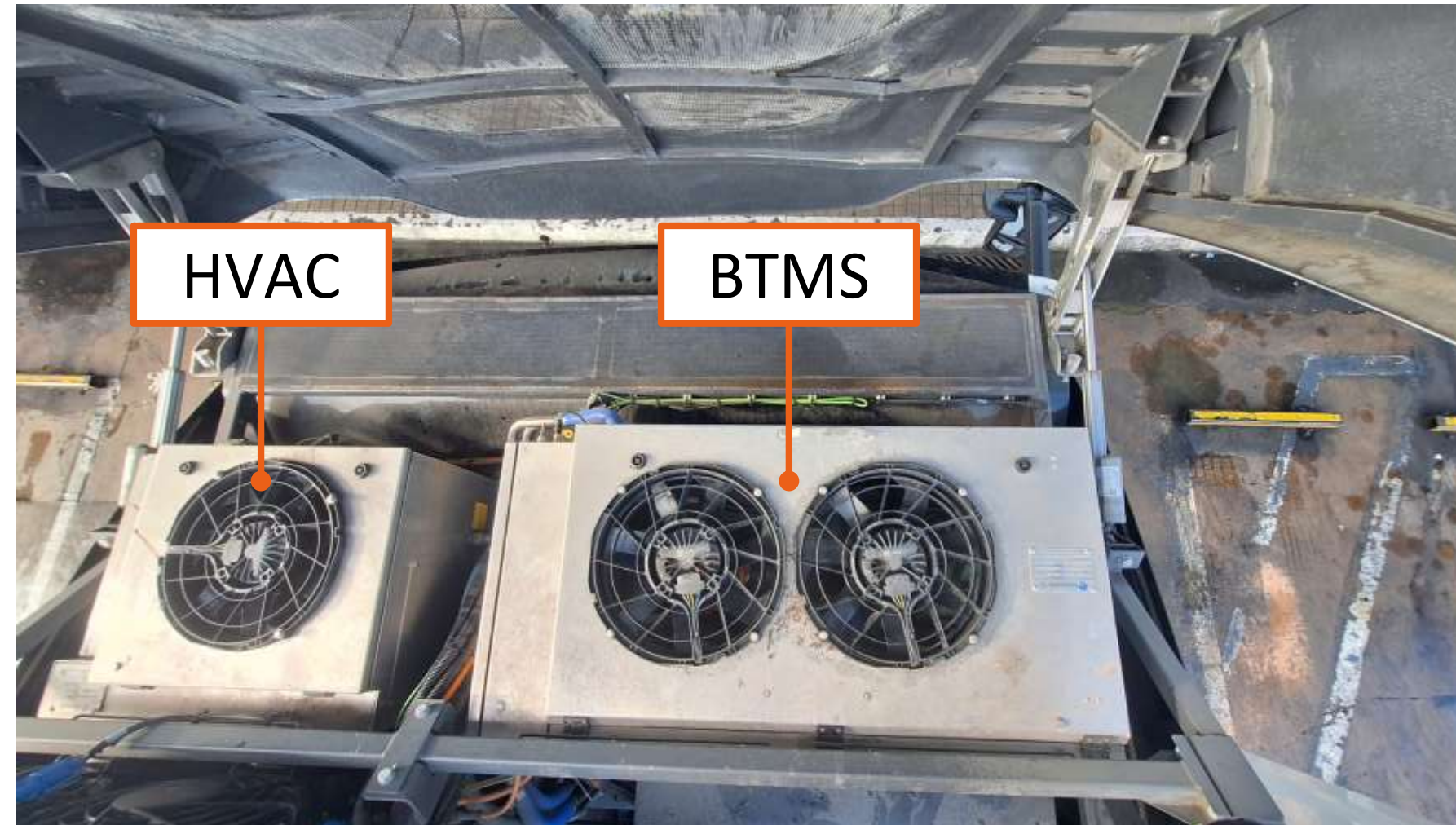

Baseline:

- Two independent systems
- Placed on top of the truck

Retrofit:

- One unified system
- Less parts, less weight
- Decreased TCO

RETROFIT





Innovation: Steering

Retrofit:

- New steering column
- New steering box

Improvement:

- Less weight
- Improved TCO



Steering column



Steering box



Innovation: IOT

Retrofit:

- Integration of TECNALIA IOT device

Features:

- Cloud connectivity
- Digital twin integration



TECNALIA IOT system



Innovation: Fleet management

Retrofit:

- Integration of DATIK fleet management ECU

Features:

- Cloud connectivity
- GPS tracking
- Drowsing detector
- Lane detector

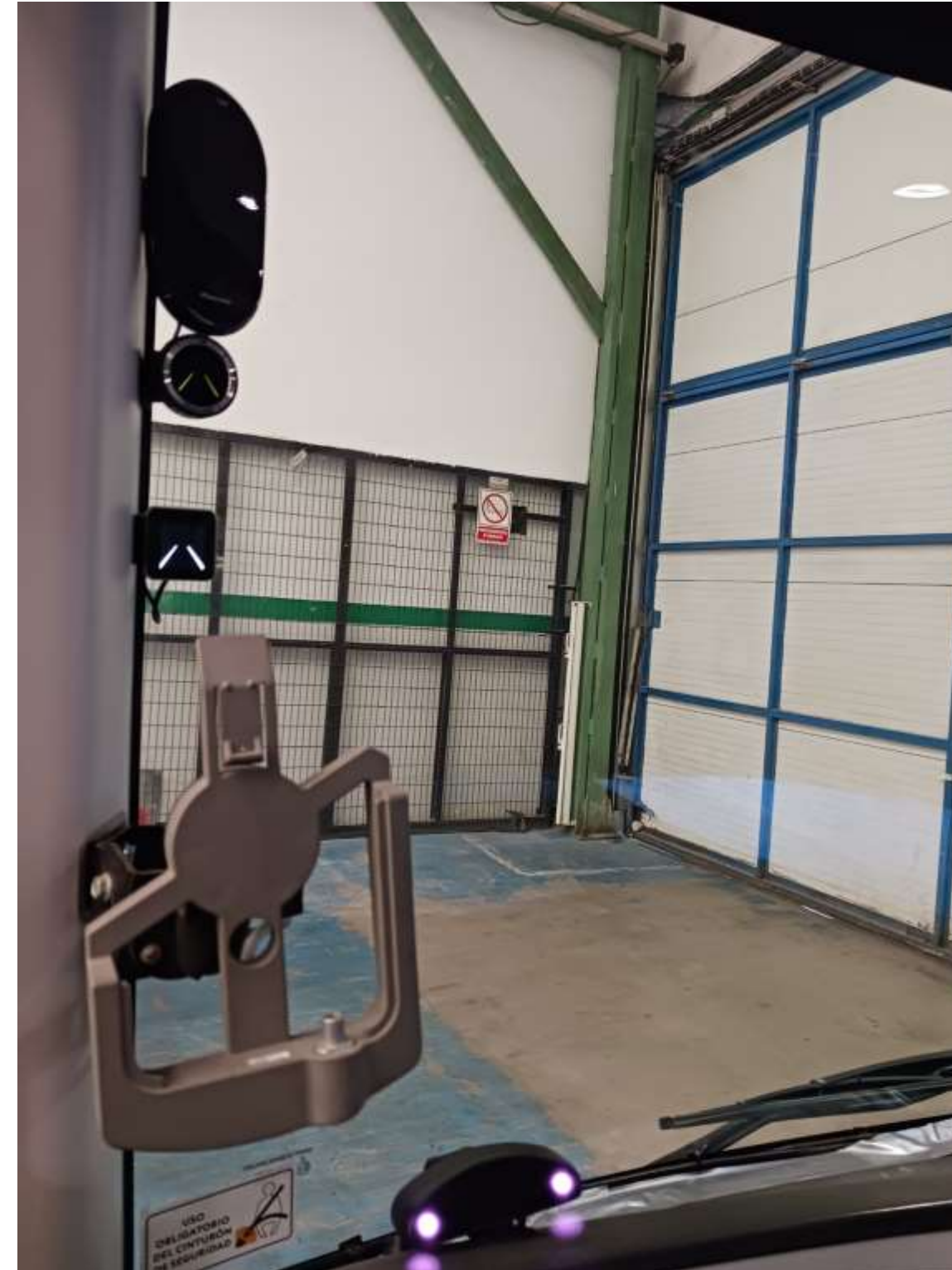

DATIK sensors and display



Use Case 2: Regular Routes

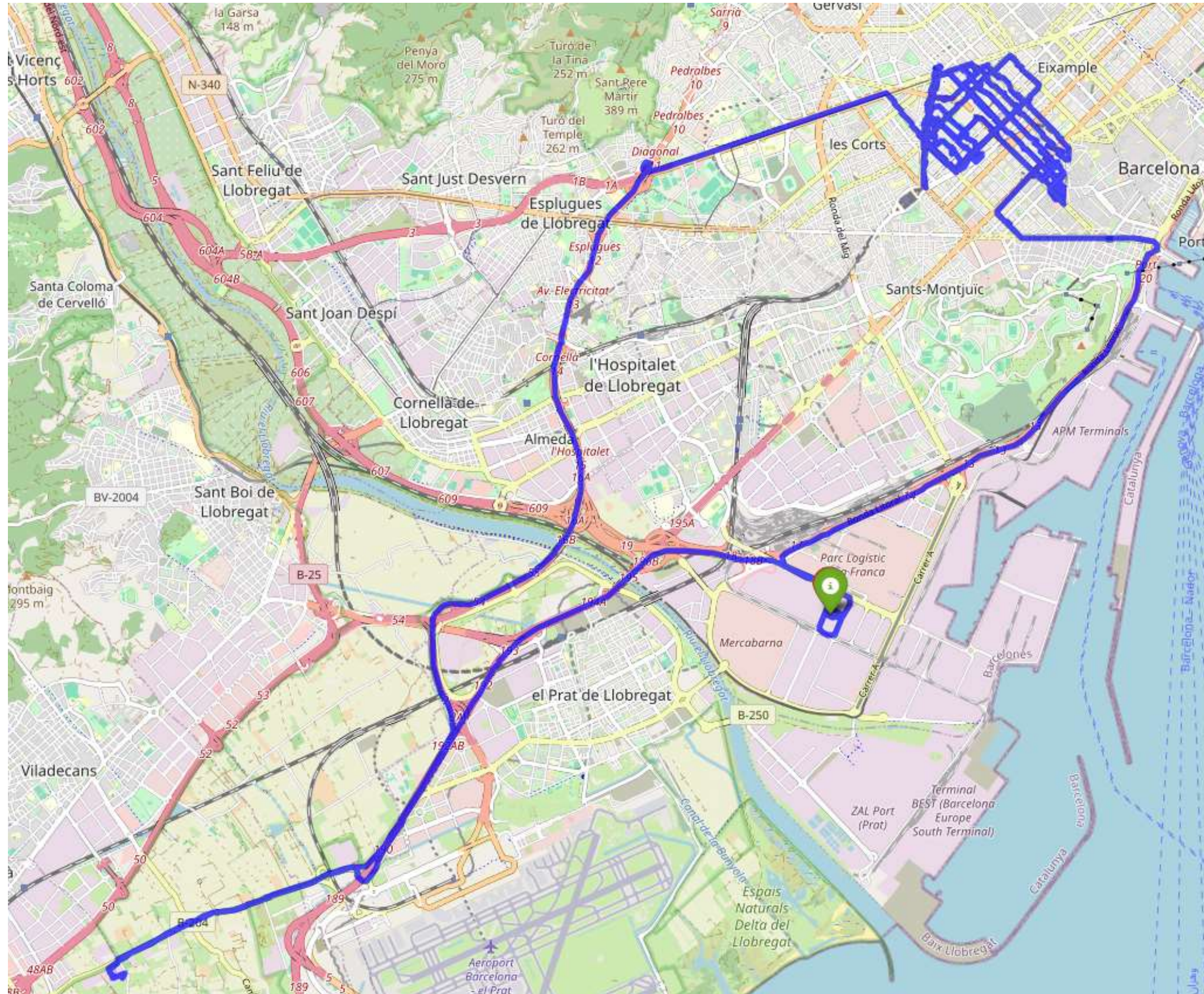

Route description:

- **Average distance:** 80 km
- **Shift:** Night
- **Waste type:** Bulky
- **Start of service:** 04/09/2015
- **Frequency:** Daily, weekdays, 1 shift
- **NextETRUCK test duration:** 6 months
- **Data:** Registered to the cloud



T7.4: Use Case #3: United Kingdom



Use case (UC) title	Back to base Logistics in UK with 19t rigid eTruck (XB-FA) and 282 kWh battery
Addressed challenge(s)	Performance and TCO optimisation through evaluation of real-life operation in a commercial pallet delivery context, operational variables: Driver, Weight, Route, Driver Style
Mission description % among all mission	“Back to base” logistics vehicle manufactured by DAF will be operated by a logistic company (Turners of Soham) in a single shift per day planning, from 2 different depots (Matthew Kibbles Transport and Jack Richards & Sons).
Charging requirements	Once, daily
Charging infrastructure	40kW Mobile Charger
Charge management	5-6 hours charging, Heliox unit

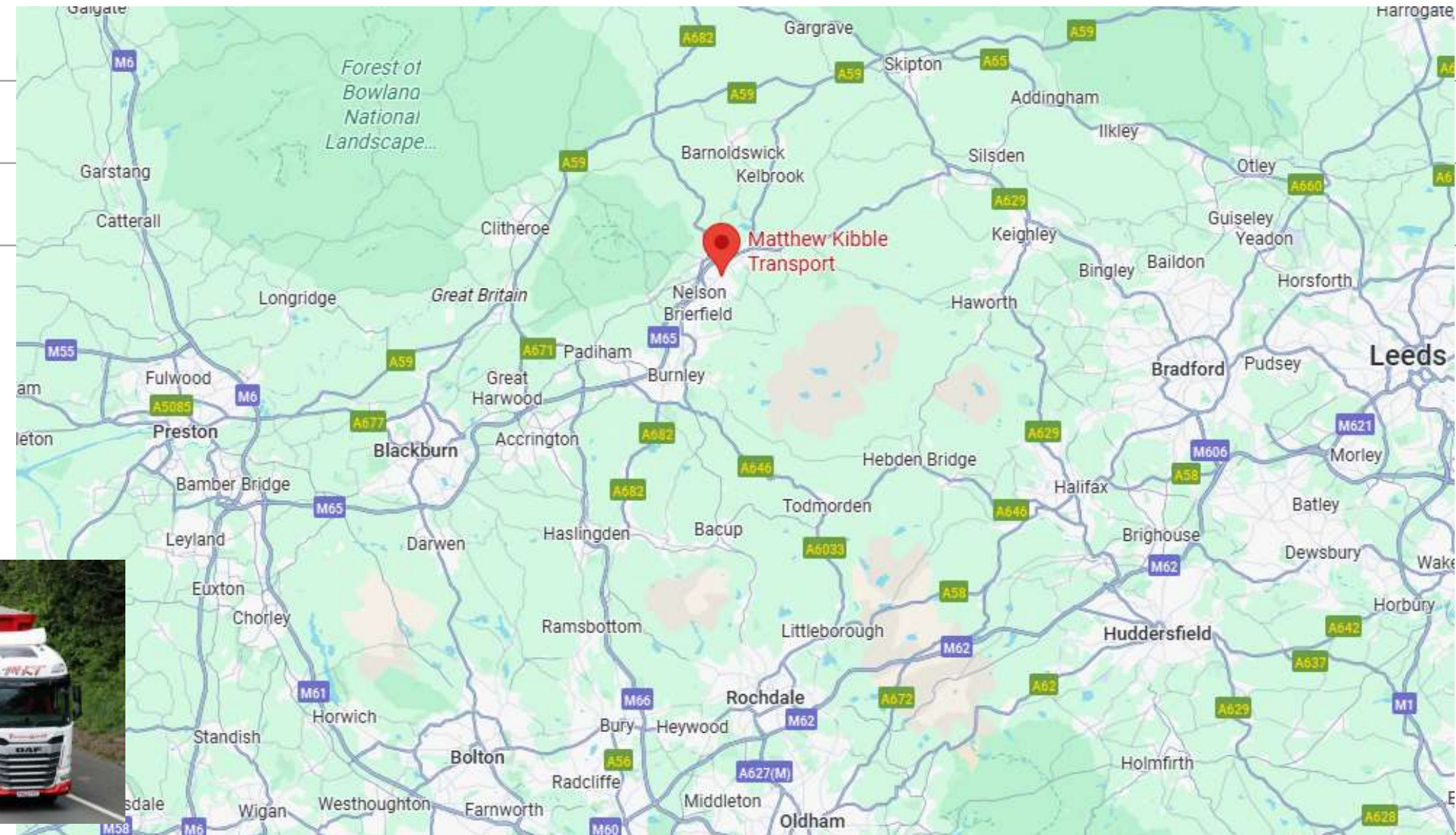

Route

- Vehicles will be deployed on various routes within **Matthew Kibbles** operation
- One truck will be used as baseline truck, with the second truck being pushed further via operational parameters
- 350km+ range to be demonstrated





XB FA ELECTRIC

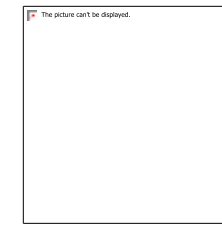

Up to 350 km *

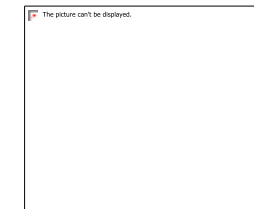

HV Batteries
141 kWh (12t only) / 210 kWh / 282 kWh

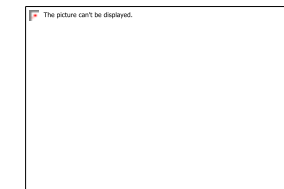

Performance rating
12 t: 120 kW; 16t: 190 kW; 19 t: 190 kW

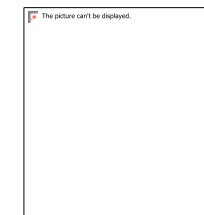

DC 150 kW + AC 22 kW

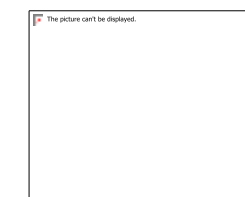

12, 16 & 19 t (solo application)
Day cab & Extended day cab
GVM allowance of 1000 kg **
(Due to max. design weight)



LEYLAND ASSEMBLY PLANT

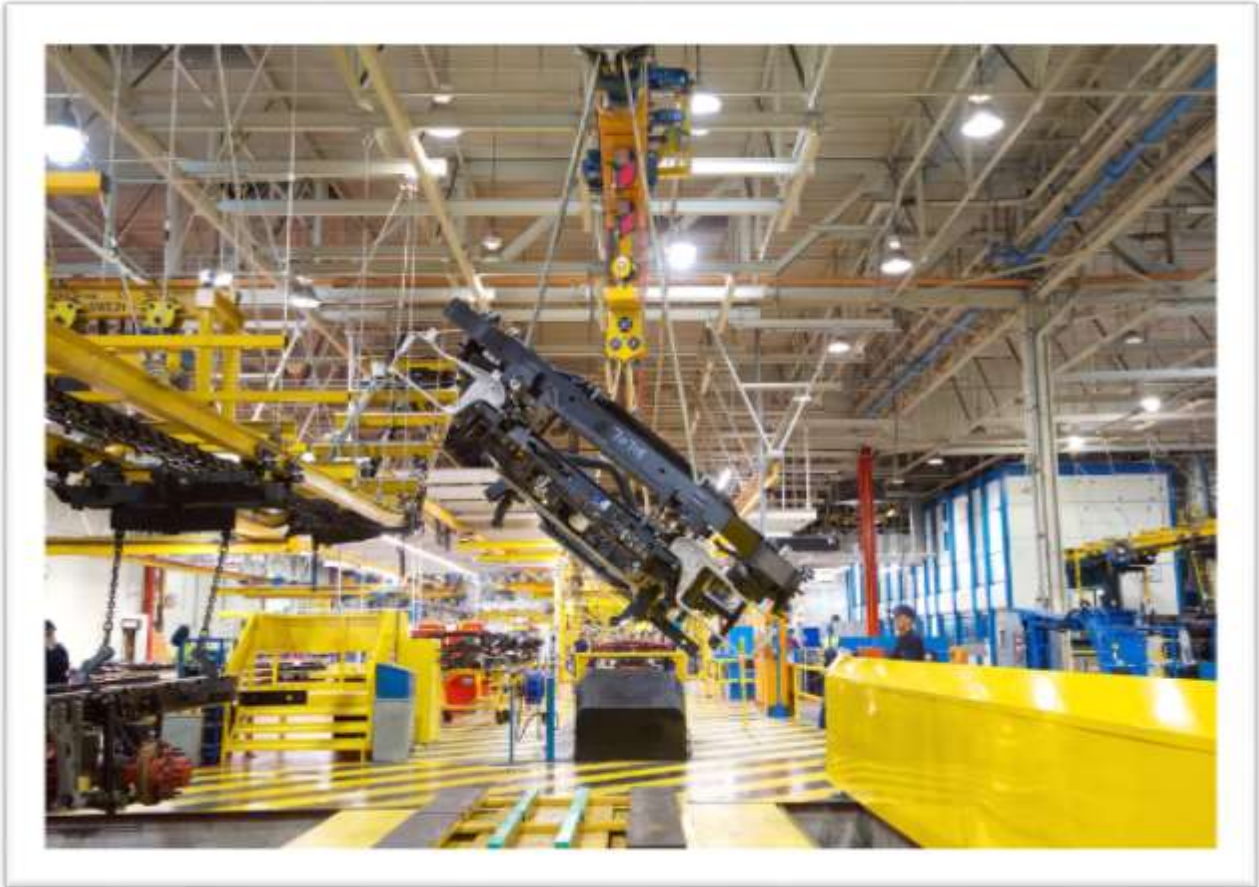



BATTERY LAYOUT XB

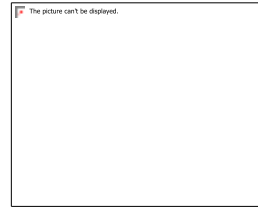

H-pack Single stack **141 kWh gross** (12t only)

H-pack Double stack **282 kWh gross**

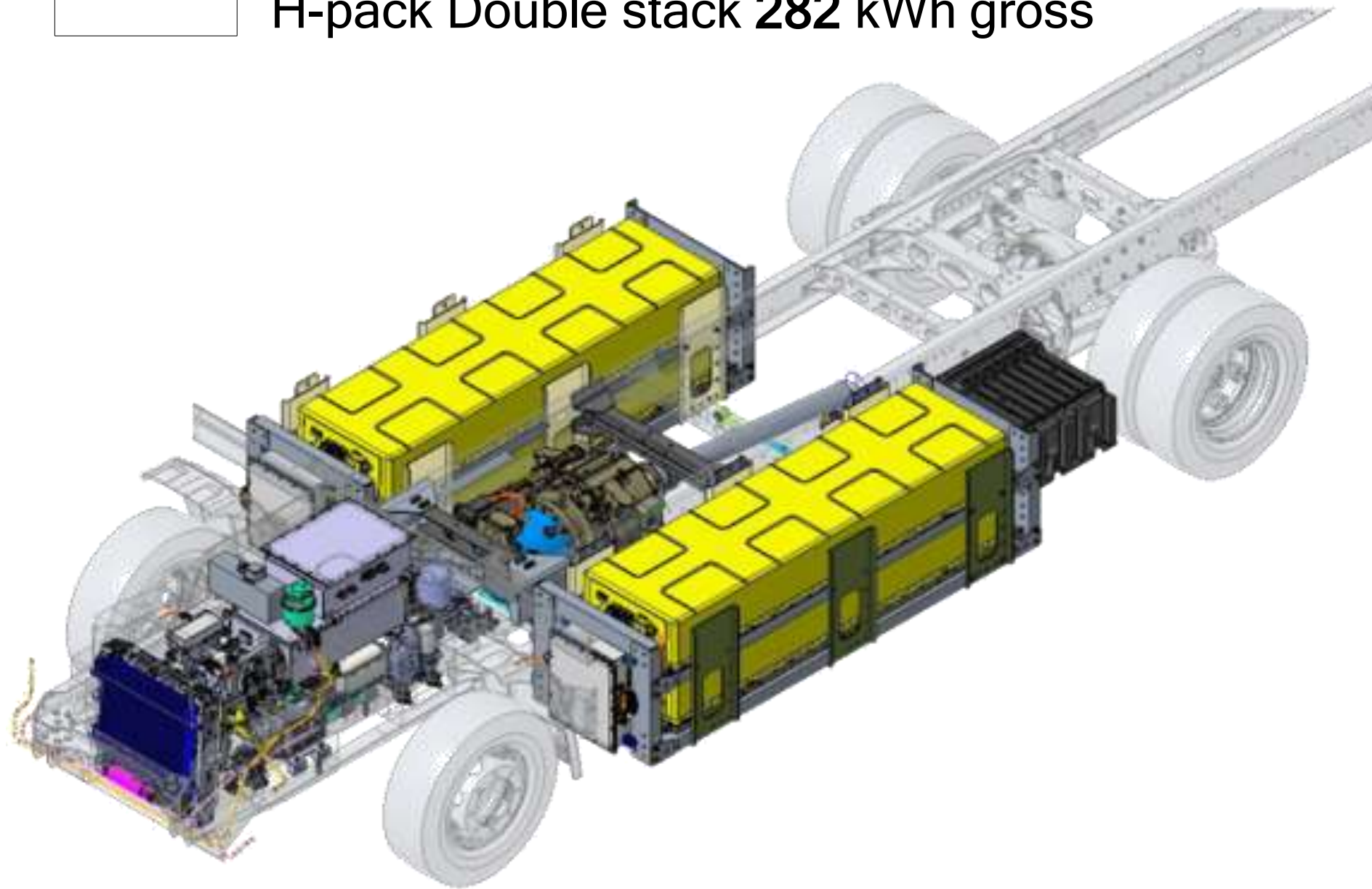



NEW GENERATION DAF MIDSHIP DRIVELINE

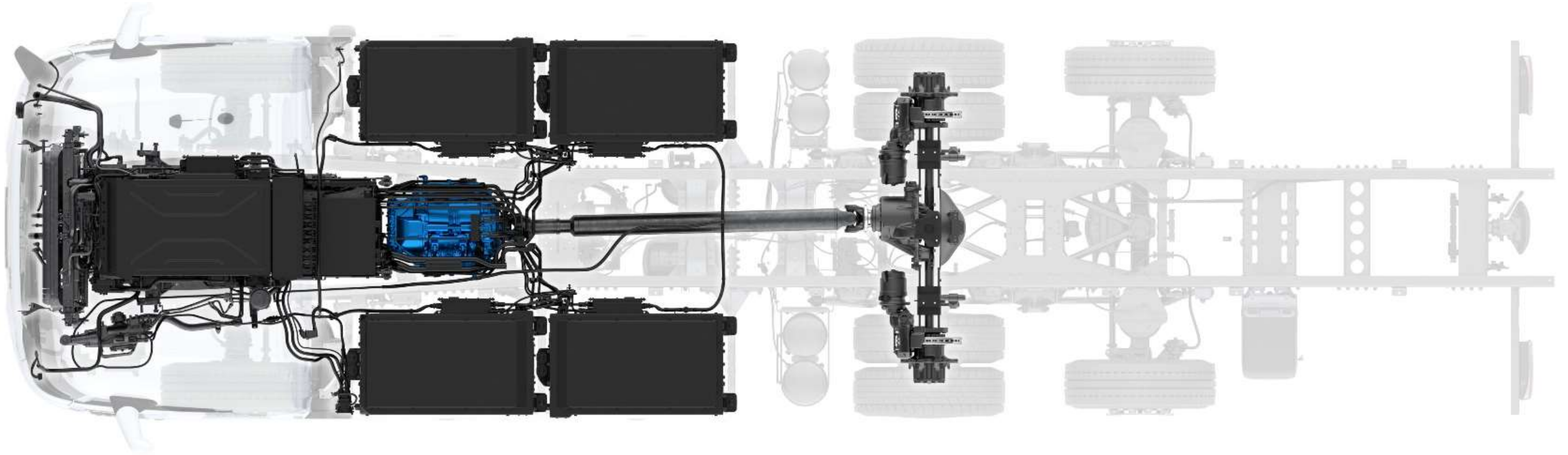



OPERATIONAL VARIABLES

We will test the vehicles across a number of variables to understand the impact on range and performance

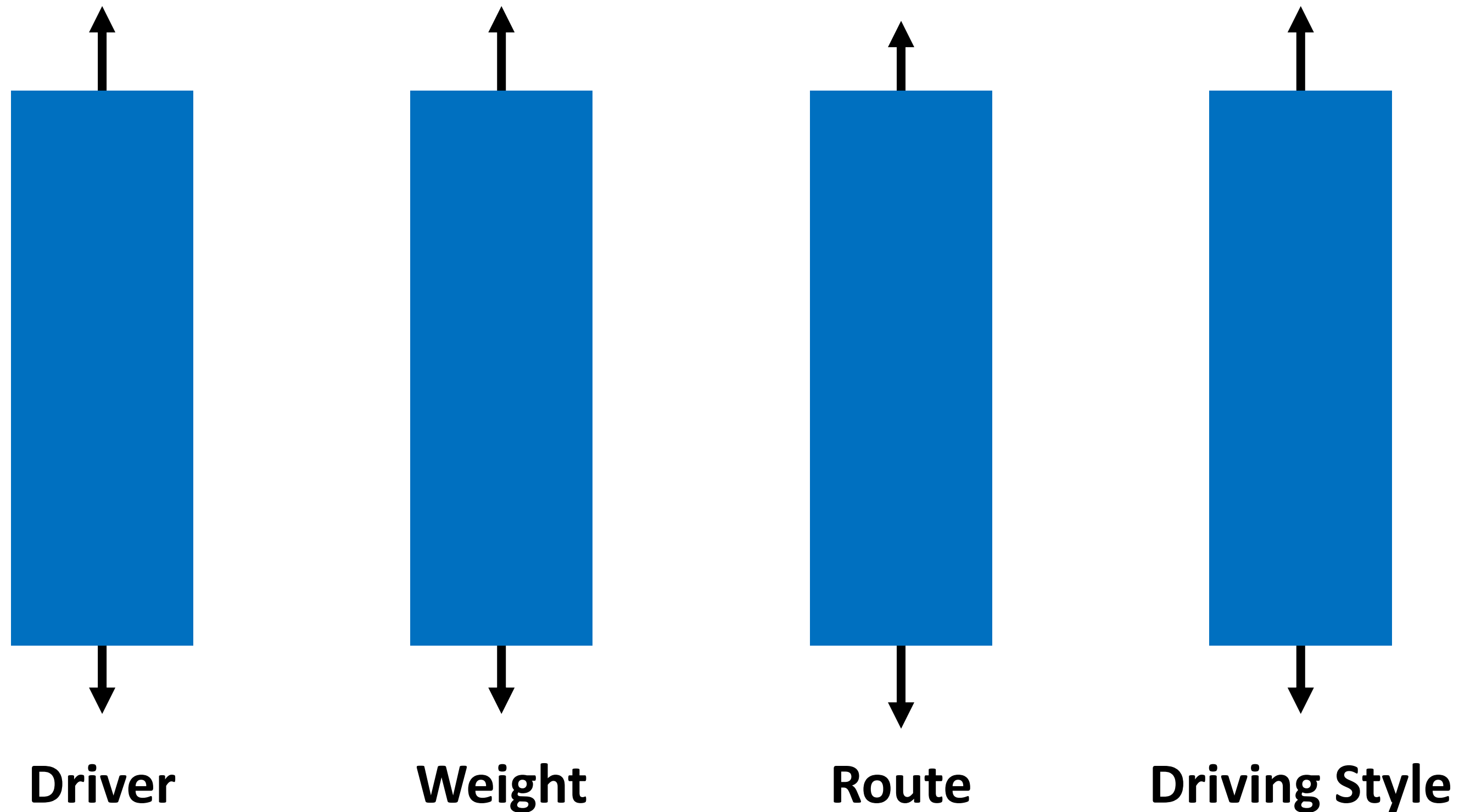



Final schedule

	2025												2026									
	1	2	3	4	5	6	7	8	9	10	11	12	1	2	3	4	5	6	7	8	9	
	31	32	33	34	35	36	37	38	39	40	41	42	43	44	45	46	47	48	49	50	51	
WP7: Use-cases and Demonstration											11											
Task 7.1 Demonstration planning, procedures, ramp-up and pilot							ramp-up	BAR			IST UK											
Task 7.2 Delivery Truck Demonstration in Turkey														Internal Demo Start	7.3						Public Road Demo Start	
Task 7.3 System demonstration of modular vehicle architecture structure for urban use electric truck demonstration in Barcelona										Demo Start												
Task 7.4 Goods distribution Urban electric truck demonstration in UK													Demo Start	7.3								
Task 7.5 Data collection and processing														7.2								
WP8: Evaluation, Impact Assessment and upscaling strategy																						
Task 8.1 Evaluation plan																						
Task 8.2 Validation																						8.2
Task 8.3 Scaling up and Impact Assessment										13												8.3
Task 8.4 Exploitation and recommendations																						8.4



Thank you for your attention!



@nextetruck



NextETRUCK



nextetruck.eu



Co-funded by the European Union

